

Technical Note

Installation: 30 Amp

Prosine 2.5/3.0

512-0063-01-01 Rev 1

Installation Diagram

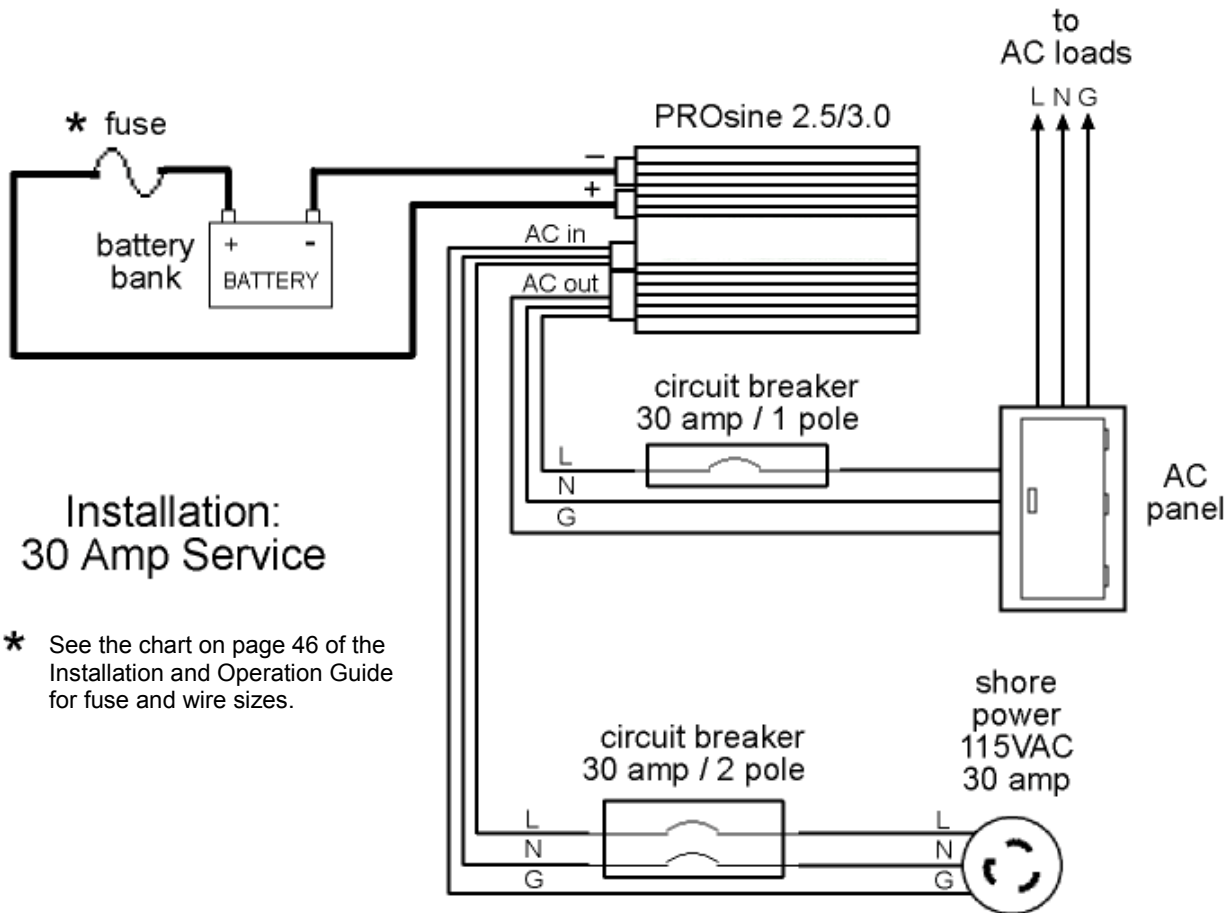

Installation: 30 Amp Service

* See the chart on page 46 of the Installation and Operation Guide for fuse and wire sizes.

Prosine is a trademark of Xantrex International. Xantrex is a registered trademark of Xantrex Technology Inc.
© 2001 Xantrex International. All rights reserved.

Technical Note: *Prosine 2.5/3.0 Installation: 30 Amp* © March 1999 Xantrex International

UNLESS SPECIFICALLY AGREED TO IN WRITING, XANTREX TECHNOLOGY INC. ("XANTREX"):

(a) MAKES NO WARRANTY AS TO THE ACCURACY, SUFFICIENCY OR SUITABILITY OF ANY TECHNICAL OR OTHER INFORMATION PROVIDED IN ITS MANUALS OR OTHER DOCUMENTATION.

(b) ASSUMES NO RESPONSIBILITY OR LIABILITY FOR LOSS OR DAMAGE, WHETHER DIRECT, INDIRECT, CONSEQUENTIAL OR INCIDENTAL, WHICH MIGHT ARISE OUT OF THE USE OF SUCH INFORMATION. THE USE OF ANY SUCH INFORMATION WILL BE ENTIRELY AT THE USER'S RISK.

Part number: 512-0063-01-01 Rev 1

Contact information:

Tel: 1-800-670-0707 (toll free in North America)

Tel: 1-604-422-2777 (direct)

Fax: 1-604-420-2145

Email: CustomerService@xantrex.com

Web: www.xantrex.com